

S.NO	CATALOG NUMBER	L	H	CONDUCTOR SIZE	SCREW SIZE
1	2AB2-1000	4.94 [125]	1.94 [49]	1000MCM-500	1-1/8-16 UN
2	2AB2-750	4.84 [123]	1.81 [46]	750MCM-1/0	15/16-16 UN

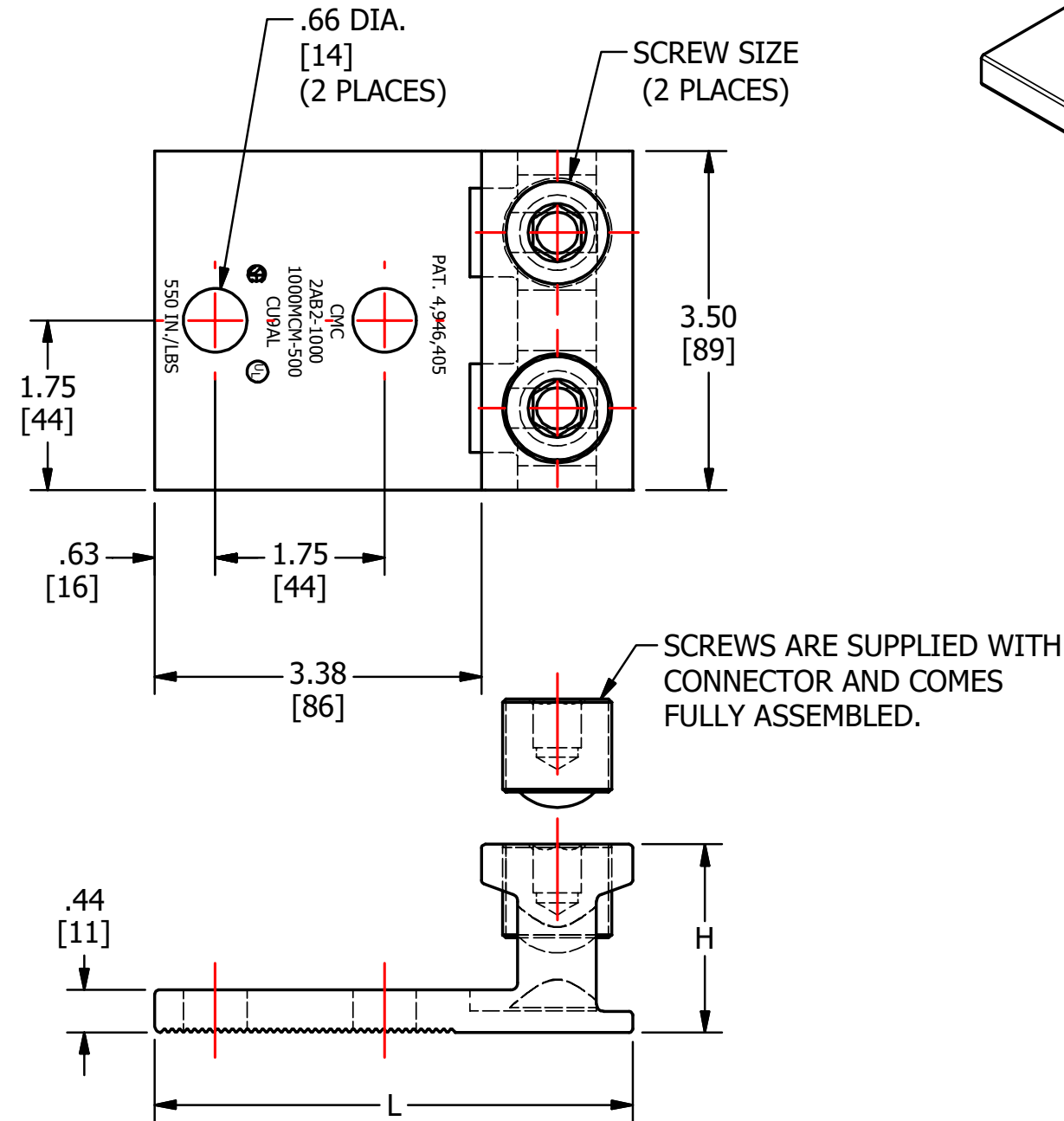
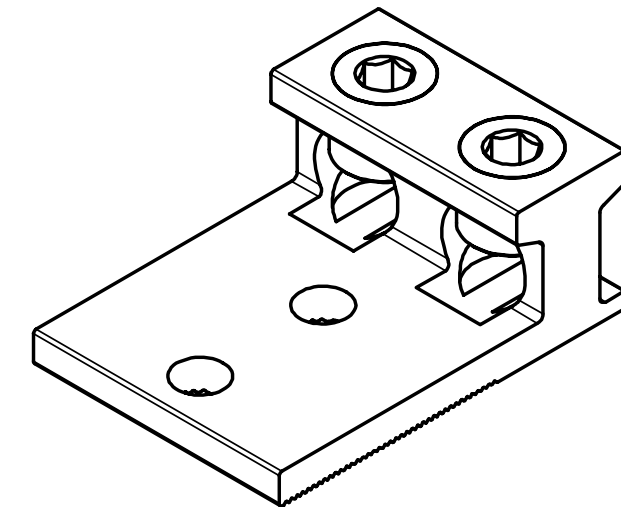

FINISH: TIN PLATE  
MATERIAL: ALUMINUM

					TO ORDER CMC PRODUCTS CALL 1-513-860-4455	DRAWN BY: TS 06-19-19	NAME OF PART: LUG ASSEMBLY	CAT. NO.: SEE TABLE
					FOR PRODUCT INFO: <a href="http://www.cmclugs.com">http://www.cmclugs.com</a>	CHECKED BY:	DWG NO: C00494212-S (CHARTED)	A
A	NEW DRAWING CREATED		06-19-19	TS		DRAWING NOT TO SCALE		SHEET NO: 1 OF 1
REV.	DESCRIPTION	ECN	DATE	INIT.				

THIS INFORMATION IS PROPRIETARY TO CONNECTOR MFG. CO. AND IS NOT TO BE DISCLOSED OUTSIDE OF CONNECTOR MFG. CO. WITHOUT A CONFIDENTIALITY AGREEMENT



**CONNECTOR MANUFACTURING CO.**

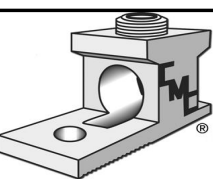

HAMILTON, OHIO